

Title		
yazu		
Size	Number	Revision
Tabloid		
Date:	21-Apr-2003	Sheet 1 of 10
File:	D:\Design\yazu\yazu6407.ddb	Drawn By:

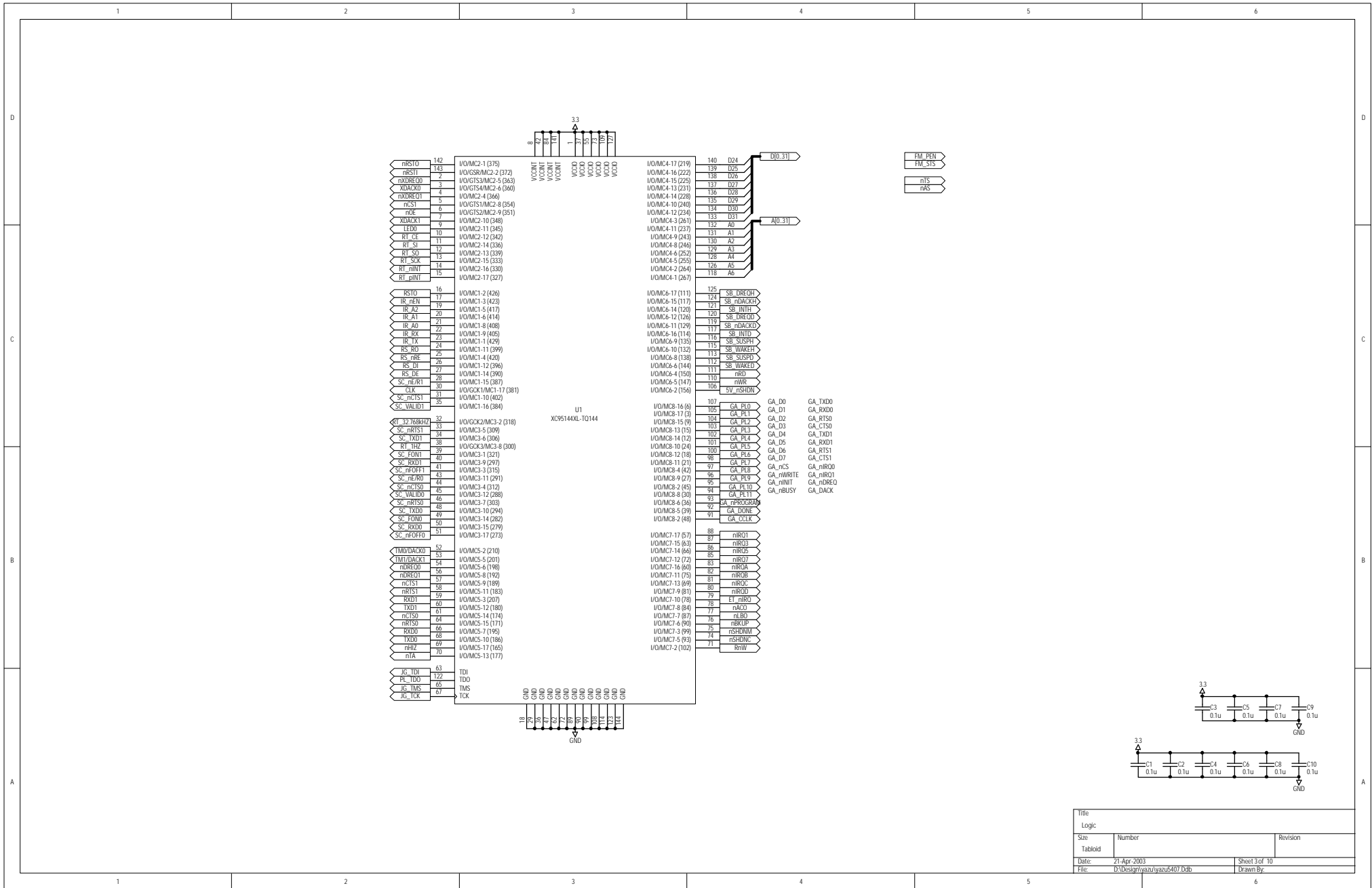

Title		Logic	
Size	Number	Revision	
Tabloid			
Date:	21-Apr-2003	Sheet 3 of 10	
File:	D:\Design\yazuyazu6407.Ddb	Drawn By:	

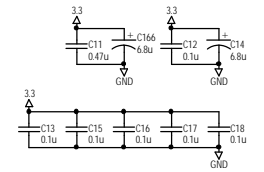
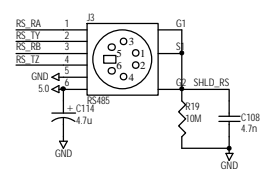
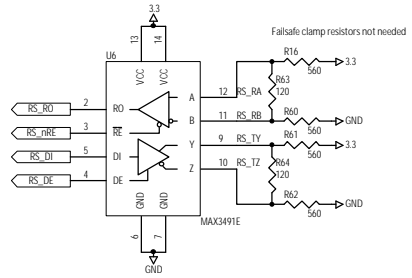
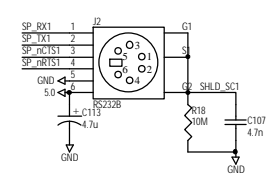
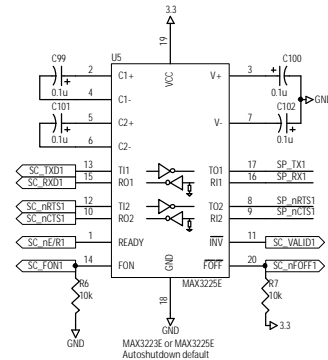
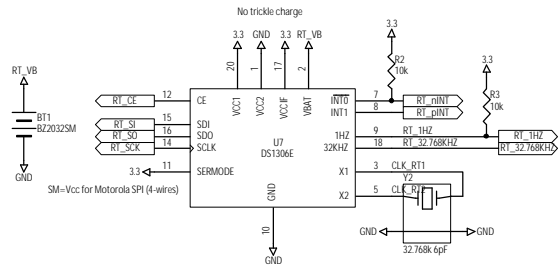
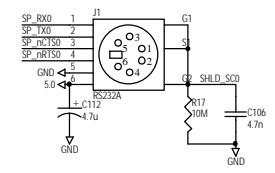
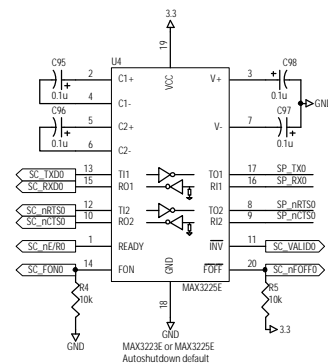
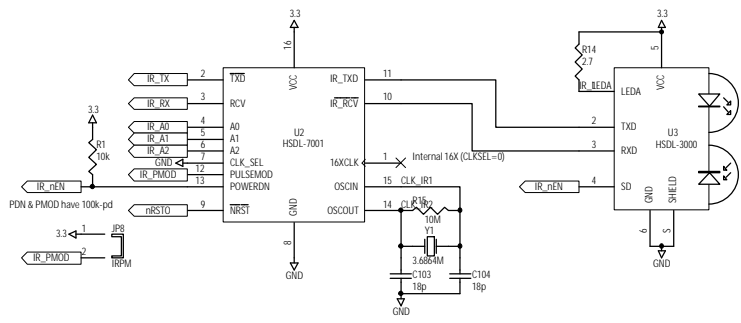

Title Peripheral		
Size	Number	Revision
Tabloid		
Date:	21-Apr-2003	Sheet 6 of 10
File:	D:\Design\yazu\yazu6407.Ddb	Drawn By:

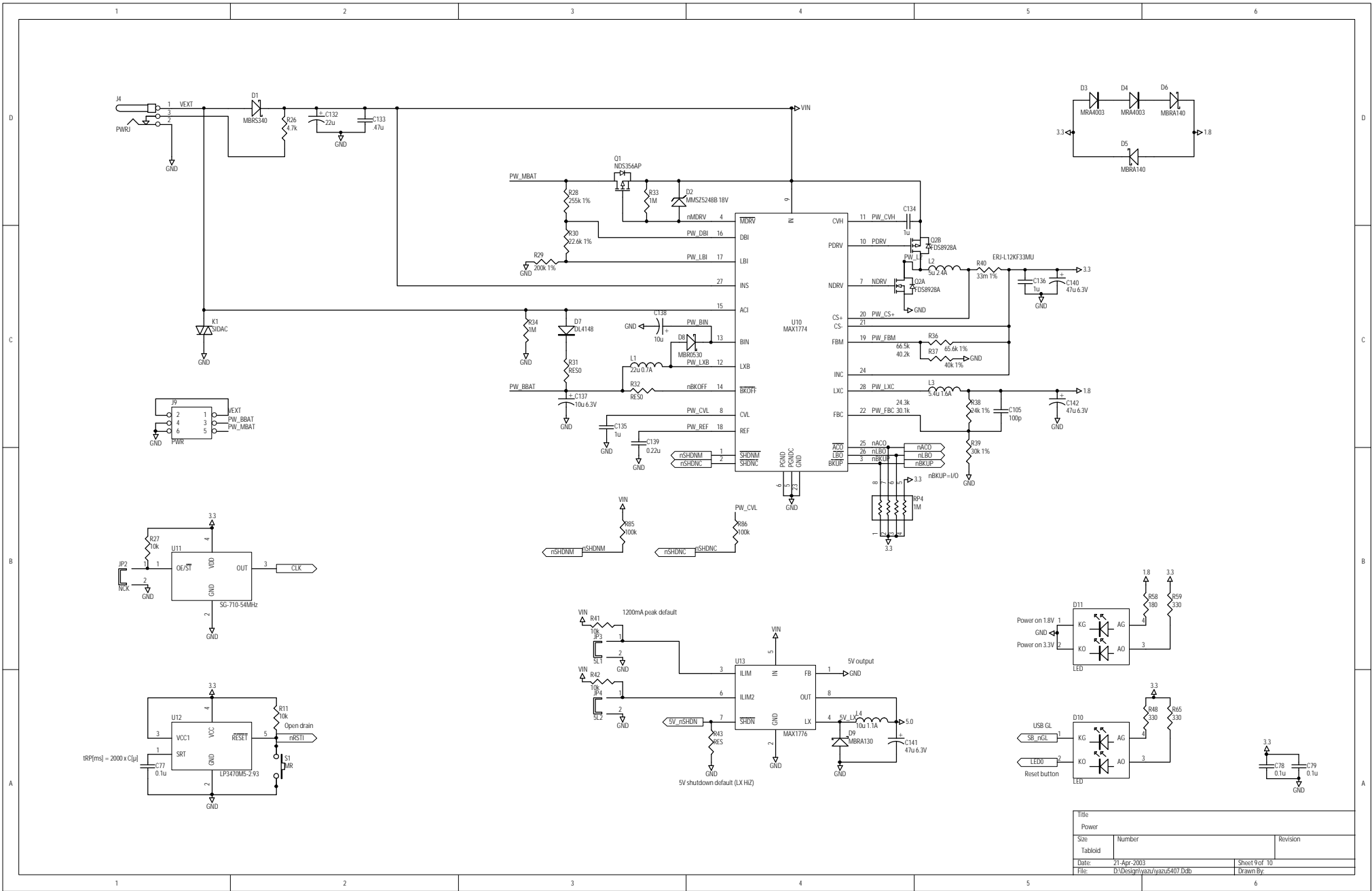

Title			Power		
Size	Number	Revision			
Tabloid					
Date:	21-Apr-2003	Sheet 9 of 10		Drawn By:	
File:	D:\Design\yazu\yazu6407.Ddb				

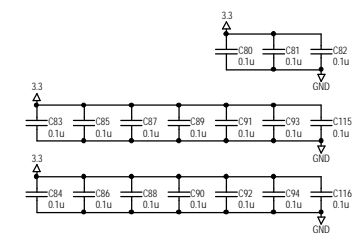
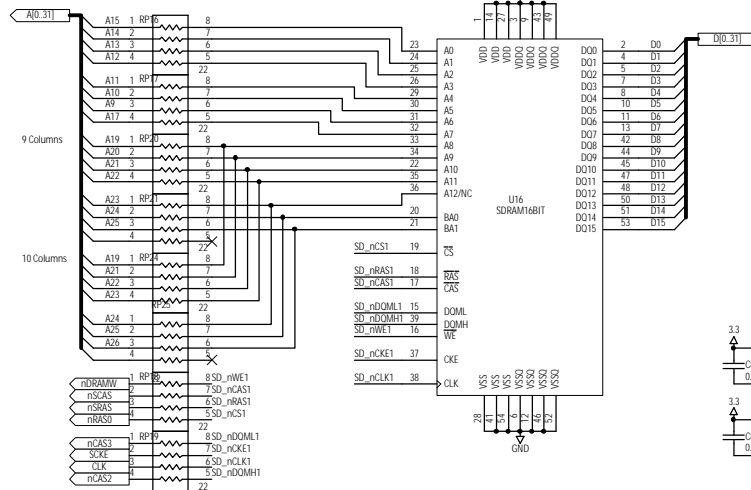
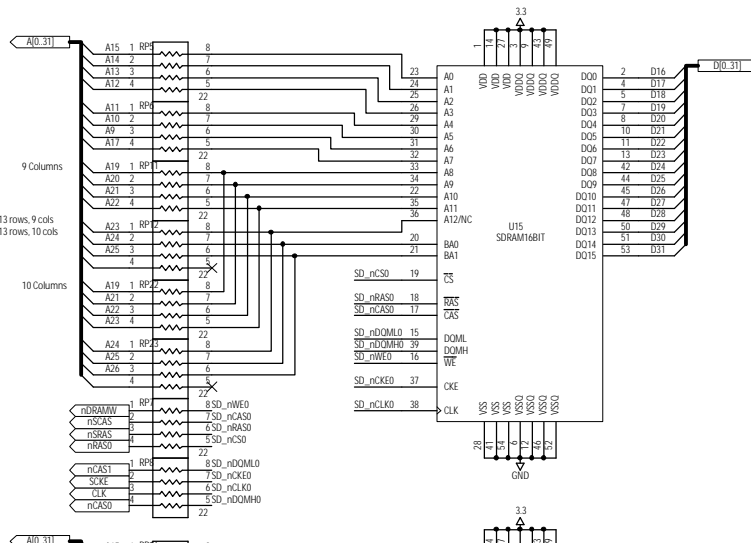
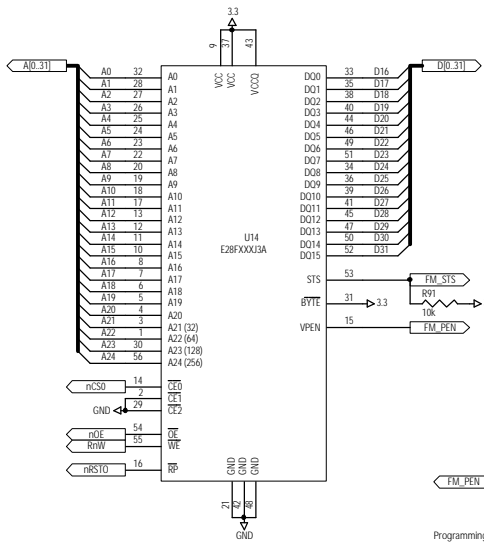

Title		
Memory		
Size	Number	Revision
Tabloid		
Date:	21-Apr-2003	Sheet 5 of 10
File:	D:\Design\yazu\yazu6407.Ddb	Drawn By:

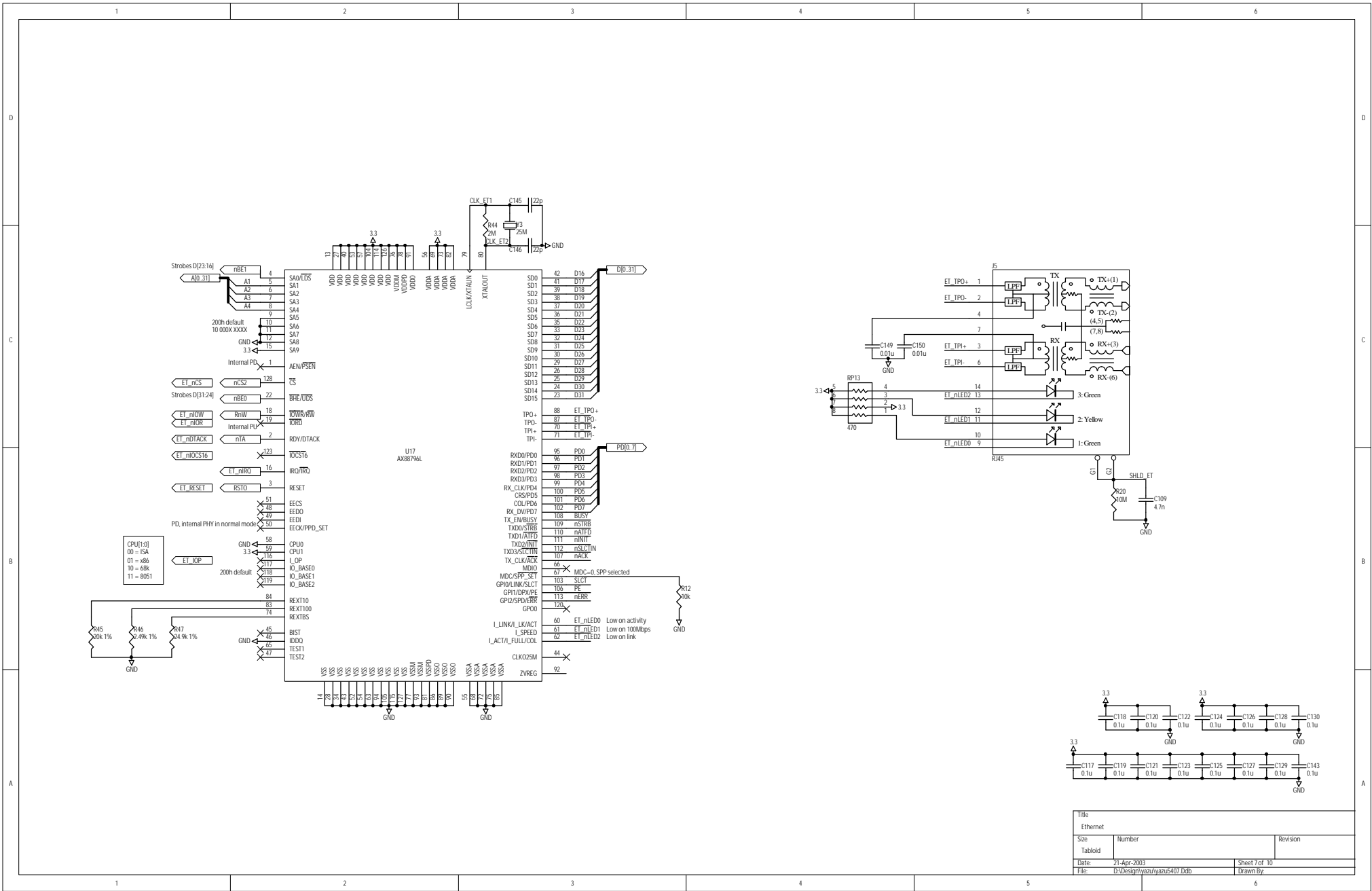

Title		
Ethernet		
Size	Number	Revision
Tabloid		
Date:	21-Apr-2003	Sheet 7 of 10
File:	D:\Design\yazuyazu6407.Ddb	Drawn By:

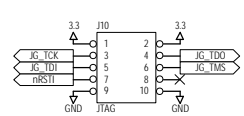
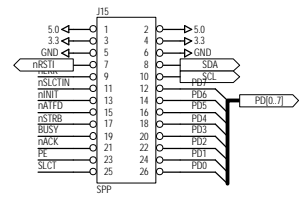
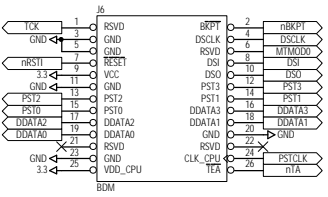

- J6:
 - 1: JG_TDI
 - 2: PL_TDO
 Short without CPLD
- J15:
 - 1: PL_TDO
 - 2: GA_TDO
 Short without FPGA
- J7:
 - 1: GA_TDO
 - 2: JG_TDO
 Short without BSC module

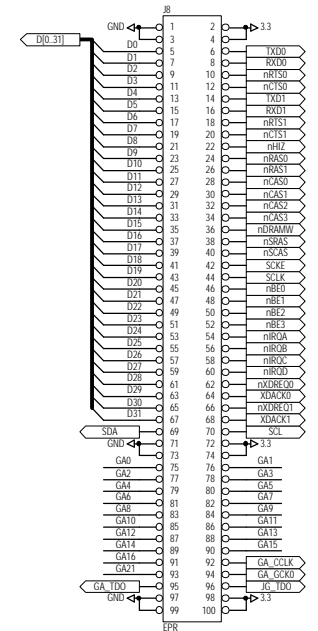
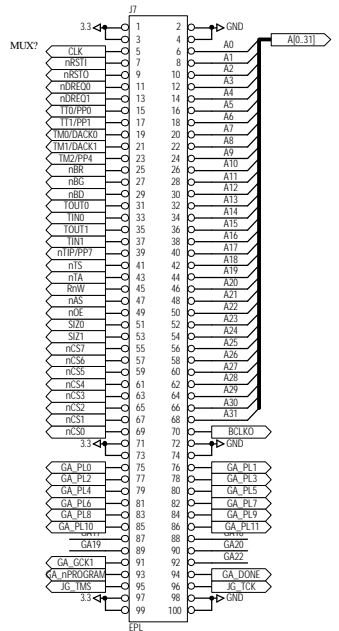

Title		
Connector		
Size	Number	Revision
Tabloid		
Date:	21-Apr-2003	Sheet 10/10
File:	D:\Design\yazu\yazu6407.Ddb	Drawn By:

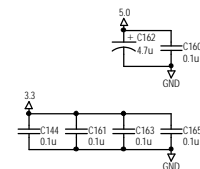
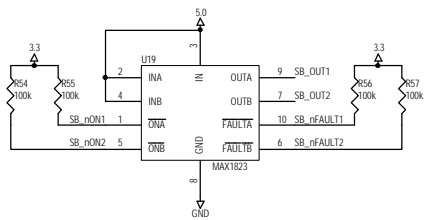
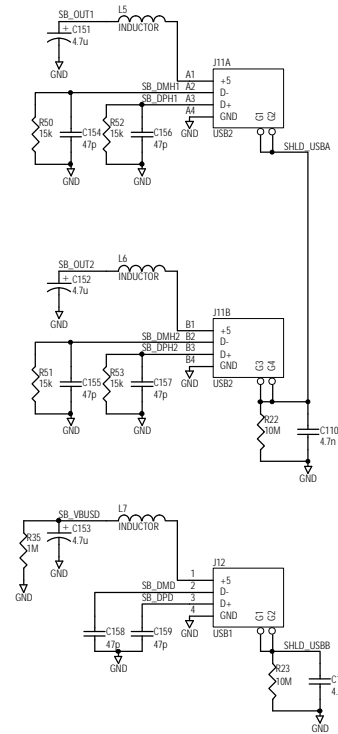
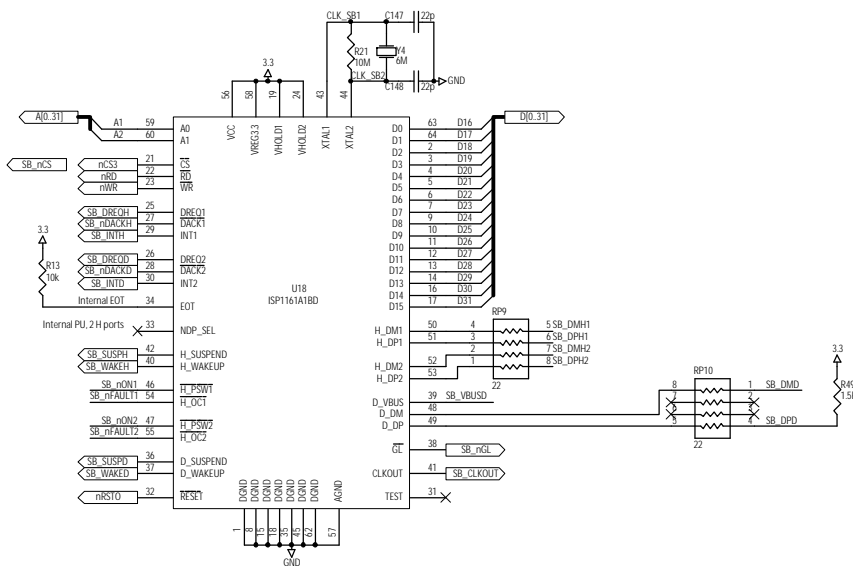

Title USB		
Size Tabloid	Number	Revision
Date: 21-Apr-2003	Sheet 8 of 10	
File: D:\Design\yazuyazu6407.Ddb	Drawn By:	